



INSTALLATION AND OPERATING INSTRUCTIONS

REFRIGERATOR FOR LP-GAS AND ELECTRIC OPERATION

RA/RM-1D

FOR YOUR SAFETY

If you smell gas:

1. Open windows and door.
2. Don't touch electrical switches.
3. Extinguish any open flame.
4. Immediately call your gas supplier.

FOR YOUR SAFETY

Do not store or use gasoline or other flammable vapors and liquids in the vicinity of this or any other appliance.

WARNING

Improper installation, adjustment, alteration, service or maintenance can cause injury or property damage. Refer to this manual. For assistance or additional information consult a qualified installer, service agency or the gas supplier.

RM2350

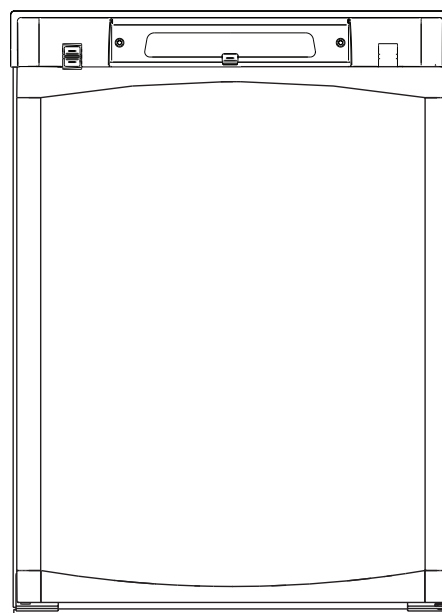

CONTENTS

REFRIGERATOR OVERVIEW	3
INSTALLATION INSTRUCTIONS	4
VENTILATION REQUIREMENTS	4
CLEARANCES	4
CONNECTIONS	6
CHANGING DOOR SWING	8
MOUNTING THE DOOR PANEL	8
REFRIGERATOR REMOVAL	8
OPERATING INSTRUCTIONS	9
LP GAS, AC AND DC OPERATION	9
REGULATING THE TEMPERATURE	9
TURNING OFF THE REFRIGERATOR	9
STORAGE COMPARTMENTS	10
PRODUCT CARE	10
MAINTENANCE & SERVICE	11
REPLACING THE HEATER	11
PERIODIC MAINTENANCE	11
TROUBLESHOOTING	12
APPENDIX A - REMOVING AND REPLACING THE SHELVES	13
APPENDIX B - REARVIEW EQUIPMENT	14
APPENDIX C - WIRING DIAGRAM	15

SYMBOLS

The following symbols are used throughout the manual:



Indicates a potentially hazardous situation, which, if not avoided, could result in death or serious injury.



Indicates a potentially hazardous situation, which, if not avoided, may result in minor or moderate injury.

CAUTION

Used without the safety alert symbol indicates, a potentially hazardous situation which, if not avoided may result in property damage.



Step-by-step instructions

INTRODUCTION

We are pleased that you have chosen this refrigerator and hope you will derive much satisfaction from using it.

The refrigerator is designed for storage of foods and storage of frozen foods and making ice.

The installation and servicing should only be carried out by an authorized/qualified person.

It is important to read through these instructions carefully before using the refrigerator. To ensure good refrigeration and economical operation, the refrigerator must be installed and used as described in these instructions.

Follow the instructions in this manual. The refrigerator is quality guaranteed. However, we are not responsible for any failures caused by improper adjustments and unfavourable installation conditions. Please contact service point or distributor service dept. for assistance.

DATA PLATE

Check the data plate, located inside the refrigerator, to ensure that you have received the right model and that it is suitable for the available gas supply and pressure.

The right gas pressure is 2.75 kPa

The right voltage is 230 - 240 volt

The right gas consumption is 1.05 MJ/h

The data plate contains e. g. the following details:

Model designation

Product number

Serial number

Since these details will be needed if you have to contact service personnel, it is a good idea to make a note of them here.

REFRIGERATOR OVERVIEW

CONTROL PANEL

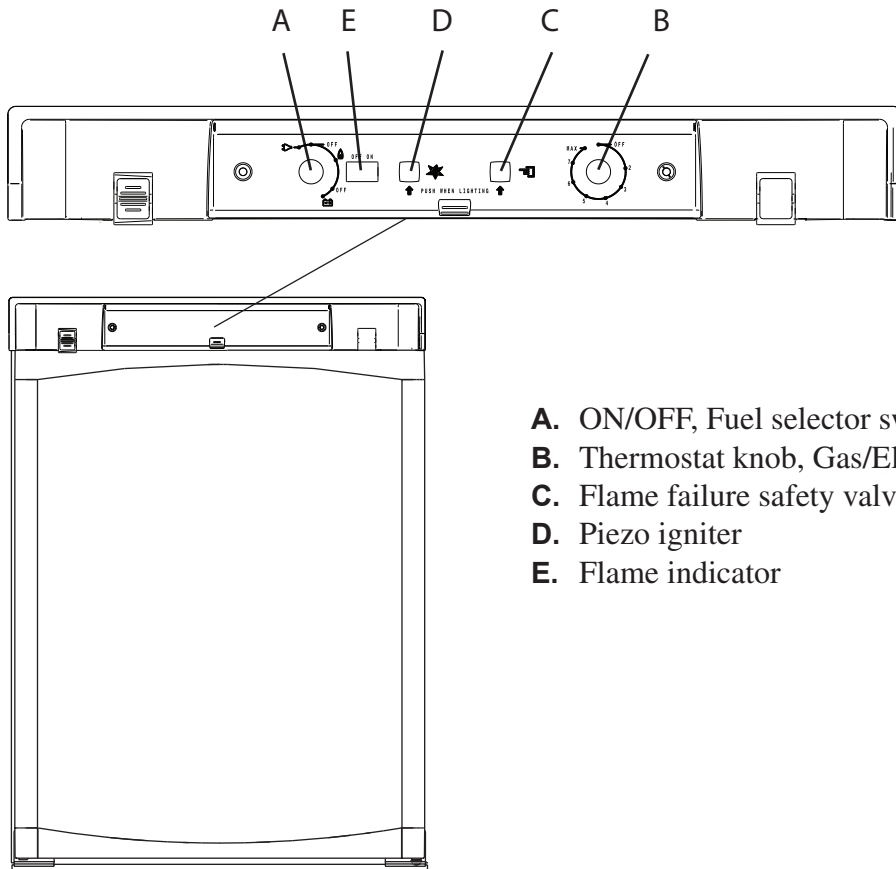

- A. ON/OFF, Fuel selector switch
- B. Thermostat knob, Gas/Electric
- C. Flame failure safety valve push-button
- D. Piezo igniter
- E. Flame indicator

ABSORPTION REFRIGERATOR SYSTEM

In an absorption refrigerator system, ammonia is liquefied in the finned condenser coil at the top rear of the refrigerator. The liquid ammonia then flows into the evaporator (inside the freezer section) and is exposed to a circulating flow of hydrogen gas, which causes the ammonia to evaporate, creating a cold condition in the freezer.

The tubing in the evaporator section is specifically sloped to provide a continuous movement of liquid ammonia, flowing downward by gravity through this section.

If the refrigerator is operated when it is not level and the vehicle is not moving, liquid ammonia will accumulate in sections of the evaporator tubing. This will slow the circulation of hydrogen and ammonia gas, or in severe cases, completely block it, resulting in a loss of cooling.

Note! Any time the vehicle is parked for several hours with the refrigerator operating, the vehicle must be levelled to prevent this loss of cooling.

When the vehicle is moving, the levelling is not critical, as the rolling and pitching movement of the vehicle will pass to either side of level, keeping the liquid ammonia from accumulating in the evaporator tubing.

GENERAL ADVICE AND INFORMATION

- Make sure defrosting is carried out periodically
- The refrigerator should be kept clean and dry with the door left open when it is not to be used for some time.
- Ensure that liquids or items with a strong odour are well packaged.
- Service and maintenance must be done on a regular schedule to keep the refrigerator operating properly, efficiently and safely. The service should be performed by qualified personnel only.
- Avoid spraying water through the refrigerator vents while washing your RV.

⚠ WARNING

**The sealed cooling system must not be opened.
It contains corroding chemicals under high
pressure.**

Sodium chromate is used for corrosion protection (less than 2 weight % of the coolant).

INSTALLATION INSTRUCTIONS

The installation, servicing and gas installation must be performed by an authorised/qualified person. The refrigerator must be installed in accordance with the manufacturers installation instructions, local gas fitting regulations, municipal building codes, electrical wiring regulations, AS5601 “Gas Installations” and any other statutory regulations.

VENTILATION REQUIREMENTS

The installation shall be made in such a manner as to separate the combustion system from the living space of the mobile home or recreational vehicle. Proper installation requires one lower fresh air intake and one upper exhaust vent.

We recommend fitting the Dometic ventilation system, which is specially developed by Dometic for this purpose. The ventilation kits must be installed and used without modification.

An opening toward the outside at floor level in the refrigerator compartment must be provided for ventilation of heavier-than-air fuel gases. The lower vent of the recommended kits is provided with proper size openings. The flow of combustion and ventilating air must not be obstructed.

The lower side vent is fitted with a panel, which provides an adequate access opening for ready serviceability of the burner and control manifold of the refrigerator. This should be centred on the back of the refrigerator. For further information contact your dealer or distributor.

Ventilation heights

MINIMUM VENTILATION HEIGHTS		
	Installation with upper and lower side vent	Installation with roof vent and lower side vent
inch	34	31
mm	864	787

CLEARANCES

MINIMUM CLEARANCES TO COMBUSTIBLE MATERIAL			
		inch	mm
Top	G	0	0
Side	K	0	0
Bottom	L	0	0
Rear	M'	1	25

¹ The distance between the rearmost part of the refrigerator and the wall behind the refrigerator.

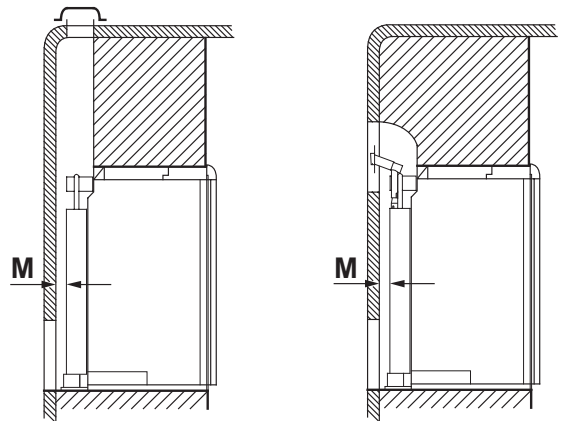
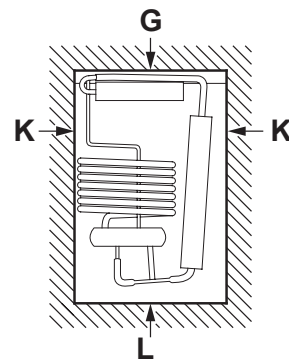

INSTALLATION INSTRUCTIONS

INSTALLING THE REFRIGERATOR IN ENCLOSURE

Dimensions

It is essential that all maximum or minimum dimensions are strictly maintained, as the performance of the refrigerator is dependent on adequate flow of air over the rear of the refrigerator.

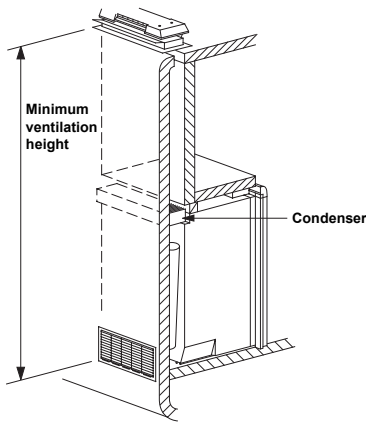
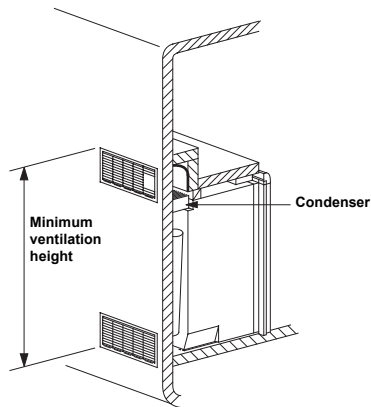

	OVERALL DIMENSIONS			RECESS DIMENSIONS		
	Height A	Width B	Depth C	Height H	Width W	Depth D
inch	30-5/32	21-7/8	22-23/32	29-3/4	20-1/2	21-3/8
mm	766	556	577	756	521	542

Side view

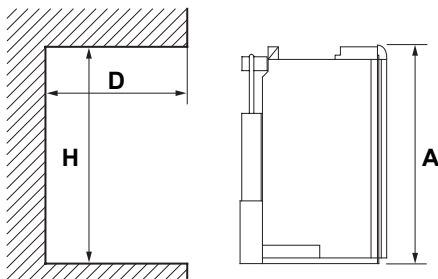

View from above

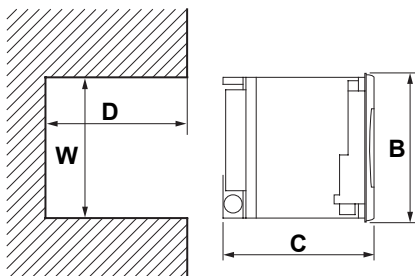

Packaging

The packaging of this appliance is design to withstand the transportation from the factory to the point where it will be installed in the recreational vehicle.

Before starting to install the appliance, please, make sure all parts of the packaging have been removed, so there will not be anything left that may come into contact with heat parts of the appliance or obstruct the combustion exhaust gases or the air movement around the cooling unit.

Installing the refrigerator

- The refrigerator must be installed in a substantial enclosure and must be level.
- **Note!** Do not install the appliance directly on carpeting. Carpeting must be removed or protected by a metal or wood panel beneath the appliance, which extends at least full width and depth of the appliance.
- The space between the storage cabinet and the top of the refrigerator should be blocked otherwise heat will become trapped in this space, making the top of the refrigerator hot, thus reducing the efficiency of the unit. All areas within the recess in which the refrigerator is installed must be sealed:
 - Make sure that there is a complete seal between the front frame of the refrigerator and the top, sides and bottom of the enclosure. A length of sealing strip is applied to the rear surface of the front frame for this purpose.
 - Apply a sealing strip to the foremost floor of the enclosure. The sealing should provide a complete isolation of the appliance's combustion system from the vehicle interior.

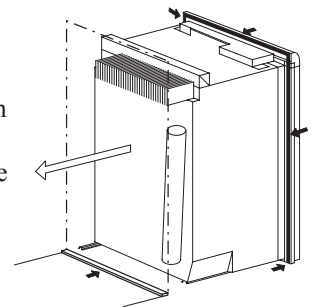

Note! Be careful not to damage the sealing strip when the refrigerator is put in place.

INSTALLATION INSTRUCTIONS

Securing the refrigerator

Failure to follow the sequence in securing refrigerator in enclosure can cause leakage between the frame and cabinet!

After the refrigerator is put in place, (insuring a combustion seal at the front frame), the refrigerator is to be secured in the enclosure with five screws (not included).

The screws have to be installed in the following order:

1. Four screws installed through the front frame.
2. One screw installed in rear base.
In the parts bag there are plugs to be snapped in the front frame to cover the four screw heads.

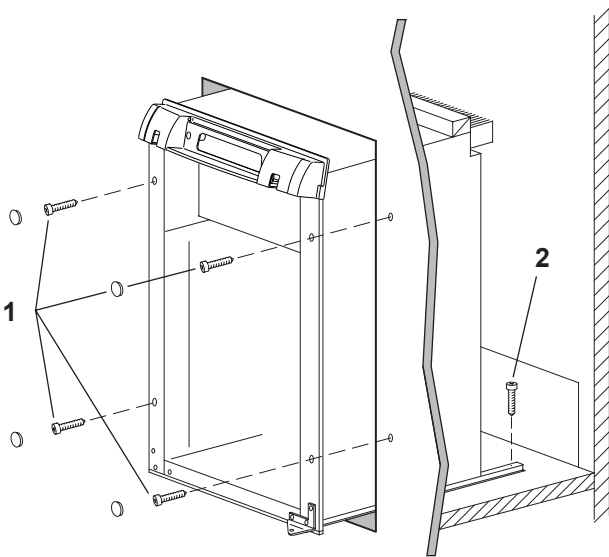

CONNECTIONS

LP gas connection

The gas installation and servicing must be carried out by an authorised person and conform to all relevant local authorities.

The refrigerator is *not* designed for operation on town gas or natural gas but for operation on LP gas, the pressure of which must be 2,75 kPa for Propane. Check that this is stated on the data plate. The gas supply system must incorporate an approved gas pressure regulator to maintain a supply pressure of 2,75 kPa.

CAUTION

Check that the gas supplied to the refrigerator is at the correct pressure!

The supply pipe should preferably be of copper. If other material is used, it must be of a type approved for use with continuously operating bottle-gas appliances and have threaded connections throughout.

All connectors etc. should be of a type specifically designed for the type and diameter of the connection pipe used, and screwed joints should be sealed with a joining compound approved for use with bottle-gas.

The gas supply pipe should be connected to the gas valve at the top of the refrigerator, by means of a suitable threaded coupling.

The gas valve is furnished with an ISO 7/1 - Rp 1/8 internal pipe thread connection.

In making the connection to the refrigerator, a union gas cock of an approved bottle-gas type must be incorporated in the supply line in a position which is readily accessible to the user. For eventual servicing purposes, the union should be positioned so as not to prevent the refrigerator from being readily withdrawn.

All completed connections should be checked for leaks with soapy water.

! WARNING

Do not use an open flame to check for gas leaks!

Testing LP gas safety shut off

The gas safety shut off must be tested after the refrigerator is connected to the LP gas supply.

To test the gas safety shutoff, proceed as follows:

1. Start the refrigerator.
2. Check that the gas flame is lit which can be observed on the flame indicator **E**. The red indicator is in the green field, (ON).
3. Close the gas valve by turning the knob **A** back to "OFF" position.
4. Wait for one minute.
5. Remove burner cover plate.
6. Open the gas valve by turning knob **A** to position (GAS) without pushing the buttons **C** and **D**.
7. Apply a non-corrosive commercial bubble solution to the burner jet.
8. No bubbles should appear at the opening of the burner jet. The presence of bubbles indicates a defective gas safety shutoff, and service is required. If no bubbles were present at the burner jet, the gas safety valve is working properly.
9. Rinse jet thoroughly with fresh water before proceeding. Be careful not to damage the burner jet.
10. Replace cover and turn the main switch OFF and back ON.
11. Normal operation of the burner should return. Allow the burner to operate for a minimum of 5 minutes.

INSTALLATION INSTRUCTIONS

Electrical connection

The electrical installation must be carried out in a proper and durable manner, taking into account all relevant regulations and codes of practice.

For mains voltage operation, it is important that the circuit to and in the caravan is effectively earthed.

The refrigerator is equipped with a three-prong (grounding) plug for your protection against shock hazards and should be plugged directly into a properly grounded threeprong receptacle. **Note!** Do not cut or remove the grounding prong from this plug.

The free length of the cord is 6 ft. (1,8 m). It is recommended the receptacle placed on the left side of the refrigerator (viewed from the rear) and approximately 4-6 inches (100-150 mm) from the floor. This will allow easy accessibility through the vent door.

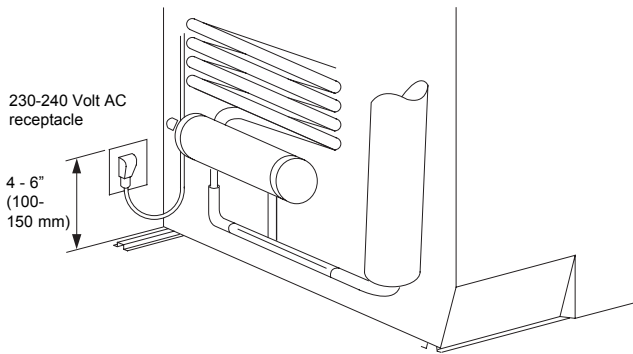

230-240 V supplies

Check that the voltage stated on the data plate is the same as the main voltage in use (230-240 V). Plug the 230-240 V refrigerator power cord into an easily accessible wall socket. Electrical leads must be routed and secured so that they cannot come into contact with hot or sharp parts of the refrigerator.

Exchange of supply cord

If the supply cord is damaged, it must be replaced by the manufacturer, its service agent or similarly qualified persons in order to avoid a hazard.

12 Volts DC Supplies

The connection is made to the terminal block marked "12 volts DC" located at the bottom left corner on the back of the refrigerator.

To avoid a voltage drop, the cross sectional area of the connecting wires between battery and refrigerator must be at least 6 mm².

To ensure safe operation, the positive lead must be fitted with a fuse rated at 20 amps.

Correct polarity must be observed when connecting to the 12 V DC supply.

Note! Do not use the body or chassis of the vehicle as a substitute for either of the two conductors. Electrical leads must be routed and secured so that they cannot come into contact with hot or sharp parts of the refrigerator.

Do not connect any other electrical equipment or lighting to the refrigerator circuit.

The connections must be clean, tight and free from corrosion. If not, a resulting voltage drop will cause a decreased cooling capacity.

Note! Do NOT operate the refrigerator on 12 V when the vehicle is parked. The amperage draw of the 12 V DC heating element can discharge a battery in a very short time.

The installation of a 12 V DC operated refrigerator requires a relay to be installed on the tow vehicle or in the caravan. The relay will automatically shut off the 12 V DC power to the refrigerator when the ignition is turned off.

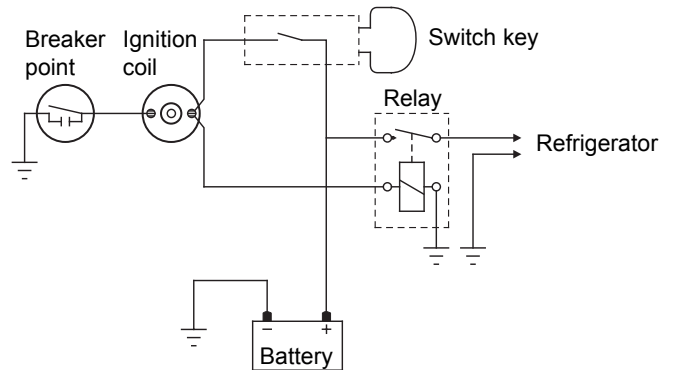

Before leaving

Once the installation is complete, test the operation of the refrigerator and instruct the user on its correct operation. If the appliance fails to operate correctly, contact your local Dometic Service provider.

INSTALLATION INSTRUCTIONS

CHANGING DOOR SWING

To change the door swing to the opposite side:

-  1. Remove the top hinge pin and lift out the door. Save the pin.
2. Remove the lower hinge pin.
3. Move the hinge pin to the hinge bracket on the opposite side of the refrigerator.
4. Remove the hinge bushing and the latch retainer on the top of the door. Save the screw to the latch retainer.
5. Take a new hinge bushing and latch retainer (from the parts bag placed inside the refrigerator).
6. The bushing and the latch retainer on the top of the door should be shifted. Use the same screw to fasten the latch retainer.
7. Remove the travel catch on the upper hinge bracket. Save the screw; re-fasten it on the hinge bracket at the opposite side.
8. The lower hinge bracket that is not in use can be removed and the screw holes covered by plastic plugs (from the parts bag).
9. Put the door on the lower hinge pin and close the door. The door gasket keeps the door in position.
10. Replace the top hinge pin.
11. Check the travel catch to make sure it works properly, that the door closes easily and that the gasket seals well on all sides.

MOUNTING THE DOOR PANEL

The refrigerator is normally delivered without door panel and it is advisable to mount the panel before the refrigerator is installed in the enclosure. The lower decoration strip and parts bag are taped inside the door.

Before starting the mounting work, read this instruction thoroughly and check that the panel dimensions are in compliance with those given in the following table:

PANEL DIMENSIONS Max thickness 5/32 (4 mm)				
	Height		Width	
	max	min	max	min
inch	26-17/64	26-3/16	19-5/8	19-17/32
mm	667	665	498	496

To mount the panel, follow these steps:

-  1. Slide the panel from the bottom of the door into the grooves on the vertical edges of the door .
2. Push the panel upwards.
3. Take the two plastic panel stops from the parts bag and put them in the two holes at the lower door frame.
4. Put the decoration strip across the door and fasten it with three screws from the parts bag.

REFRIGERATOR REMOVAL



-  1. Before working on the refrigerator, make sure the 230- 240 V AC voltage and 12 V DC voltage leads are disconnected.
2. Shut off the gas supply at the LP tank.
3. Disconnect the gas supply line.
Always use a back up wrench when loosening and tightening connections.
4. Cap the gas supply line, loosen the screws anchoring the refrigerator to the enclosure and slide the refrigerator out of the compartment.
5. When replacing the refrigerator make sure that the sealing strips are properly positioned.
6. Replacement is the reverse of removal. Check all connections for gas leaks.

OPERATING INSTRUCTIONS

GAS, AC AND DC OPERATION

LP gas operation

Before starting the refrigerator, open the shutoff valve of the gas bottle (check that there is enough gas). Open any on-board shutoff valve.

- 
1. Start the refrigerator by turning knob **A** to position  (GAS).
 2. Turn the thermostat knob **B** to position 4.
 3. Press and hold button **C** and push button **D** for the piezo igniter several times to light the burner. This can be observed on the flame indicator **E**. When the flame is lit, the red indicator is in the green field. (ON).
 4. After the gas is lit keep button **C** pressed for 10 s. Release the button and check that the red indicator is in the green field, (ON).

Note! After changing an LP tank, or after a long shut off period, the gas line is likely to be filled with air. You may have to repeat the lighting procedure several times to purge the air out of the gas lines.

WARNING

Whilst mobile:

- Do not operate the refrigerator on LP gas.
- Turn off the gas bottle.

230-240 V AC OPERATION

Before operating the refrigerator, check that the voltage stated on the data plate is the same as the main voltage in use.

- 
1. Check to be sure that the power cord is properly connected to the power supply.
 2. Turn the knob **A** to the position marked “AC” for 230-240 volt AC operation.
 3. Turn the thermostat knob **B** to position 4.

12 V DC OPERATION

Only operate your refrigerator on 12 V DC when the engine of the vehicle is running - otherwise your battery will soon be discharged.

- 
- Turn the knob **A** to the position marked “DC” for 12 V DC operation.
Note that there is no thermostat function on 12 V DC operation, the refrigerator works continuously.

REGULATING THE TEMPERATURE

The refrigerator is equipped with a thermostat that can be adjusted by turning the knob **B** to different setting to maintain the desired cabinet temperature.

Gas operation

- At “OFF”, the thermostat closes its main valve and the burner runs continuously at the bypass rate, just enough to keep the burner lit.
- At “MAX”, the thermostat allows the burner to remain on high flame continuously.

AC operation (230-240 V AC)

- At “OFF”, the contacts in the thermostat are open and the heating elements are off.
- At “MAX”, the heating element is “ON” continuously. Lowest cabinet and freezer temperatures are obtained at this setting.

The thermostat can be adjusted between “MAX” and “OFF” to obtain the desired cabinet temperature. The closer the knob is to “MAX” - the colder the cabinet temperature. The closer the knob is to “OFF” - the warmer the cabinet temperature.

When the thermostat reaches the set temperature, it will cut the burner back to bypass or, in electric operation (230-240 V AC), shut off the heating element. The setting of the thermostat is not critical, but we recommend it be adjusted to maintain a dry frost on the cooling fins. Adjust the thermostat knob closer to “MAX” when the outside temperature becomes warm.

TURNING OFF THE REFRIGERATOR

- 
- To shut off the refrigerator turn the knob **A** to “OFF”.

If the refrigerator will not be in operation for a period of weeks, it should be emptied, defrosted, cleaned and the door left ajar. Use the travel catch to hold in this position. The ice tray should also be dried and kept outside the cabinet.

OPERATING INSTRUCTIONS

STORAGE COMPARTMENTS

WARNING

Do not store explosive substances in the refrigerator, such as cigarette lighter gas, gasoline, ether or the like.

Food storage compartment

The food storage compartment is completely closed and unventilated, which is necessary to maintain the required low temperature for food storage. Consequently, foods having a strong odour or those that absorb odours easily should be covered. Vegetables, salads etc. should be covered to retain their crispness. The coldest positions in the refrigerator are under the cooling fins and at the bottom of the refrigerator. The warmer areas are on the upper door shelves. This should be considered when placing different types of food in the refrigerator.

Frozen food storage compartment

Quick frozen soft fruits and ice cream should be placed in the coldest part of the compartment, which is at the bottom of the aluminium liner. Frozen vegetables, may be stored in any part of the compartment. This compartment is not designed for deep or quickfreezing of food. Meat or fish, whether raw or prepared, can be stored in the frozen food storage compartment provided they are precooled first in the refrigerator. They can be stored about three times longer in the frozen food compartment as compared to the fresh food compartment. To prevent food from drying out, keep it in covered dishes, containers, plastic bags or wrapped in aluminium foil. Ice cubes can be made in the freezer compartment. For faster ice making, the tray should be placed in direct contact with the bottom of the freezer compartment. Ice making is accelerated if the thermostat knob **B** is turned to the “MAX” setting. It is a good idea to do this a few hours before the anticipated need for ice, but be sure to turn the thermostat back to normal setting, usually about mid-setting when the ice is formed. Food in the lower compartment may be frozen if the setting is left on “MAX” position.

PRODUCT CARE

Defrosting

-  1. Shut off the refrigerator by turning the knob A to “OFF” position.
2. Empty the refrigerator, leaving the drip tray under the finned evaporator.
3. Leave the cabinet and freezer doors open. Filling the ice tray with hot water and placing it on the freezer shelf can reduce defrosting time.

Defrost water

Defrost water runs from the drip tray to a receptacle at the rear of the refrigerator where it normally evaporates. With a lot of defrost water as a result of heavy frosts build up on the cooling fins, remove the drip tray and turn it around. Replace the drip tray with the outlet on the right side of the drip tray and put a bowl under the outlet.

4. When the ice has melted, dry the interior of the refrigerator with a clean cloth.
5. Replace the drip tray to its original position and connect the draining tube.
6. Replace all food and set the thermostat to “MAX” for a few hours. Then reset the thermostat to the desired setting, usually at mid-setting.

CAUTION

Do not use:

- **A knife or an ice pick, or other sharp tools to remove frost from the freezer shelves. It can create a leak in the ammonia system.**
- **A hot air blower. Permanent damage could result from warping the metal or plastic parts.**

Cleaning the refrigerator

Always keep the refrigerator clean. Cleaning the refrigerator is usually done after it is defrosted or put into storage. To clean the interior liner of the refrigerator, use lukewarm weak soda solution. Use only warm water to clean the finned evaporator, gasket, ice tray and shelves.

Note! Never use strong chemicals or abrasives to clean these parts, as the protective surfaces will be damaged.

It is important to keep the area at the back of the refrigerator clean. Check the lower vent, upper vent and area between these openings for any obstructions such as bird/insect nests, spider webs, etc. Clean the coils on the back of the refrigerator. Use a soft bristled brush to dust off the coils. Keep the refrigerator area free from combustible material, gasoline and other flammable vapours or liquids.

MAINTENANCE & SERVICE

Service and maintenance must be done on a regular schedule to keep the refrigerator operating properly, efficiently and safely. The service should only be performed by a qualified technician who is familiar with LP gas systems and refrigerators.

REPLACING THE HEATER

The refrigerator is equipped with two electrical heaters, one for 230-240 VAC and one for 12 V DC.

To replace the heater proceed as follows:

1. Unplug the refrigerator power cord from the 230-240 volt AC outlet. Disconnect the 12 V DC power to the refrigerator.
2. Remove the refrigerator from the enclosure.
3. Disconnect the heater leads at the top of the refrigerator.
4. With a pair of pliers, unfold the lug holding the lid of the boiler casing and open the lid.
5. Remove some insulation wool so that the heater is accessible.
6. Turn and lift the heater out of its pocket.
7. Fit the new heater into the pocket.
8. Reconnect the heater leads at the top.
9. Put back the insulation and close the lid of the boiler.
10. Reinstall the refrigerator in the enclosure.
11. Check all connections for gas leaks.
12. Connect 230-240 V power cord to the outlet.
13. Reconnect or turn on the 12 V DC power.

PERIODIC MAINTENANCE

Checking the connections

Check all connections in the LP gas system (at the back of the refrigerator) for gas leaks. The LP gas supply must be turned on. Apply a non-corrosive bubble solution to all LP gas connections. The appearance of bubbles indicates a leak and should be repaired immediately by a qualified serviceman.

Checking the LP gas pressure

The LP gas pressure should be checked and the main regulator readjusted if pressure is incorrect. The correct operating pressure is 2,7 kPa. The correct place to measure the LP gas pressure is at the test port just ahead of the burner jet.

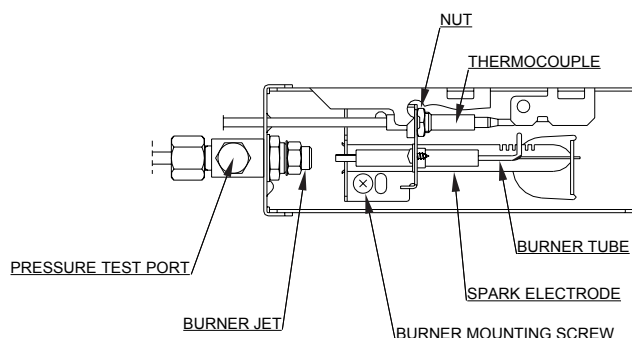

Cleaning the flue and burner

Inspect the flue baffle. It should be reasonably clean and free of soot. Heavy soot formation indicates improper functioning of the burner.

The flue and burner both require cleaning in the following manner:

1. Unplug the refrigerator power cord from the 230-240 V AC outlet. Disconnect or shut off the 12 V DC power to the refrigerator.
2. Close the gas valve by turning the knob A to "OFF".
3. Remove cover from the burner housing.
4. Disconnect the wire from the high voltage electrode.
5. Remove the burner mounting screw and remove the burner assembly.
6. Lift out the wire and flue baffle from the top of flue tube.
7. Clean the flue from the top using a flue brush. Blowing compressed air into the flue will not properly clean soot and scale out of the flue tube.
8. Replace the flue baffle.
9. Clean burner tube with a brush.
10. Blow out burner with compressed air.
11. Before removing burner jet, clean burner area of soot and scale that fell out of flue tube.
12. Remove the burner jet. Soak the jet in wood alcohol and blow out with compressed air. Reinstall and tighten burner jet.

⚠ WARNING

Do not use a wire or pin when cleaning the burner jet as damage can occur to the precision opening. This can cause damage to the refrigerator or create a fire hazard.

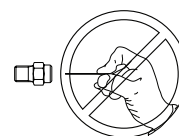

13. Reinstall burner, being careful that the end of the burner fits into the slot on the burner bracket.



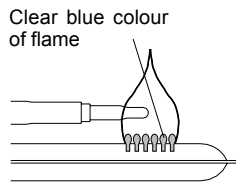

MAINTENANCE & SERVICE

14. Check to make sure the slots are centred under the flue tube and that the thermocouple is positioned properly (tip of thermocouple extends over two slots of burner). Note that the colour of the flame should be clear blue over the slots of the burner.

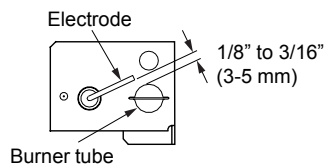

15. Be sure to reconnect the wire to high voltage electrode. Check the electrode for proper location and gap.



16. Open the gas valve by turning knob **A** to  (GAS).
17. Check all fittings for leaks with soapy water.
18. Connect 230-240 volt power cord to the outlet and reconnect the 12 V DC power.
19. Check LP gas safety shutoff.

TROUBLESHOOTING

Refrigerator does not cool properly

- Burner jet clogged.
- Check level of refrigerator.
- Venting problem.
- Heavy frost buildup on evaporator fins.
- Flue baffle not inserted properly in flue tube.
- Improperly set thermostat.
- Burner dirty.
- LP gas pressure low at burner.
(Set main regulator so pressure does not drop below 2,7 kPa at pressure tap.)
- Burner not located properly under flue tube.
- Burner damaged.

Odour from fumes

- Dislocated burner
- Damaged burner
- Dirty flue tube

APPENDIX A - REMOVING AND REPLACING THE SHELVES

General instruction. The number of shelves and position may vary between different refrigerator models.

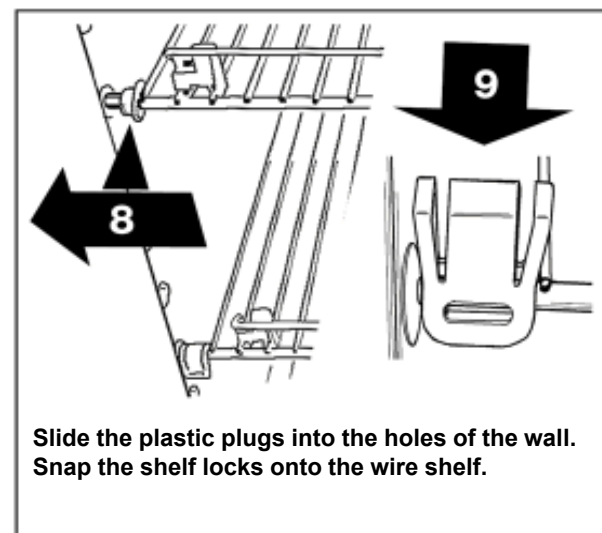
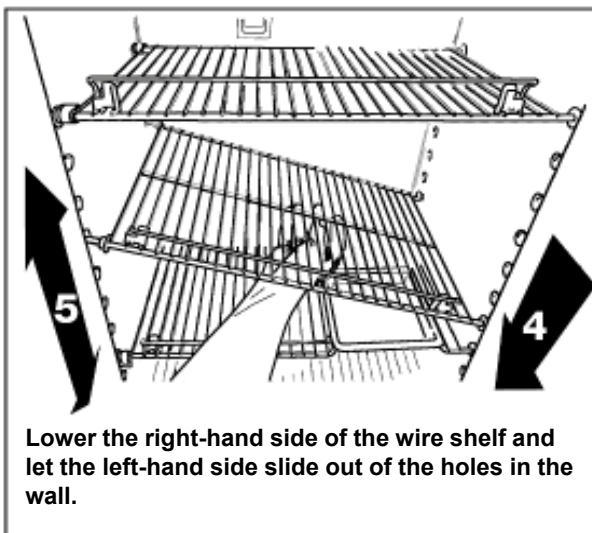
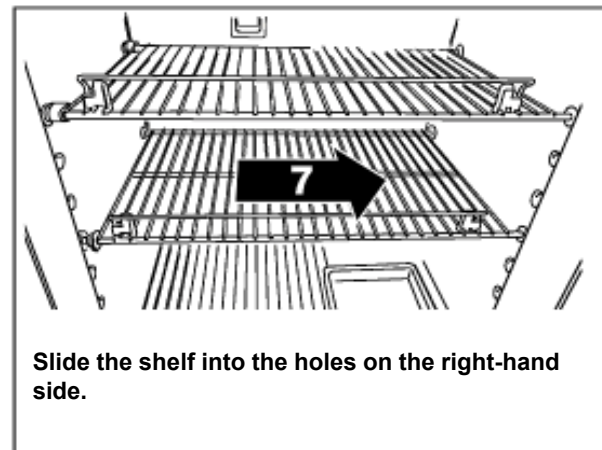
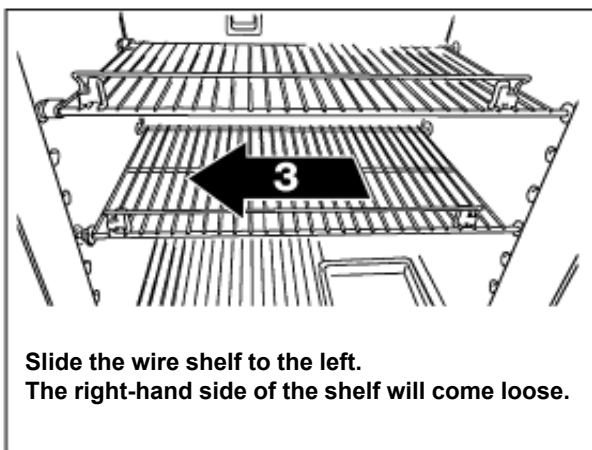
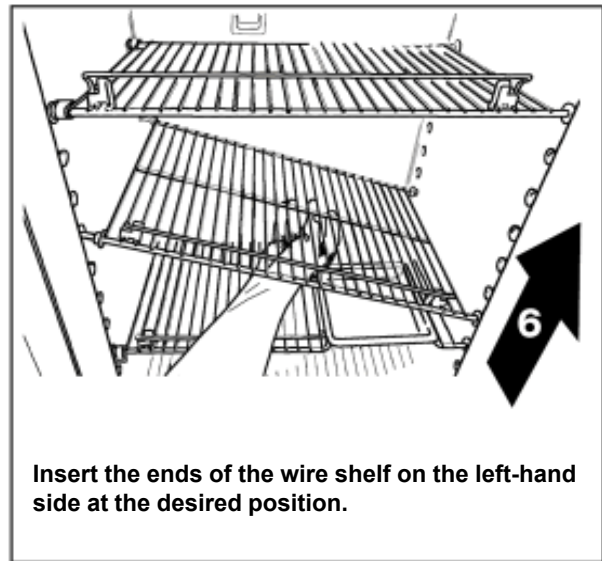
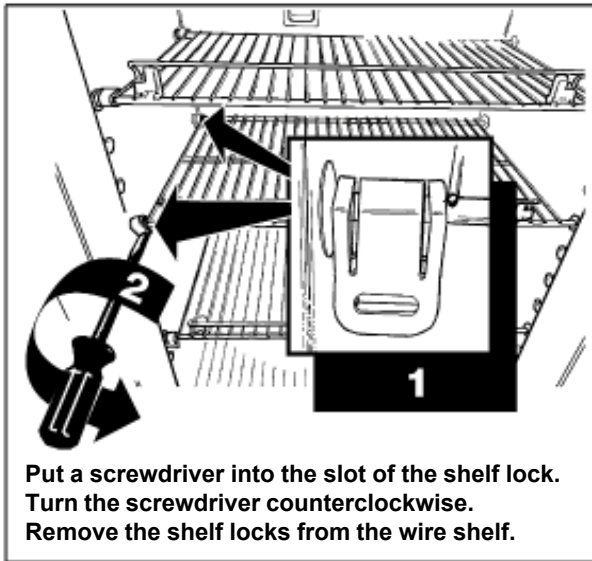

APPENDIX B - REARVIEW EQUIPMENT

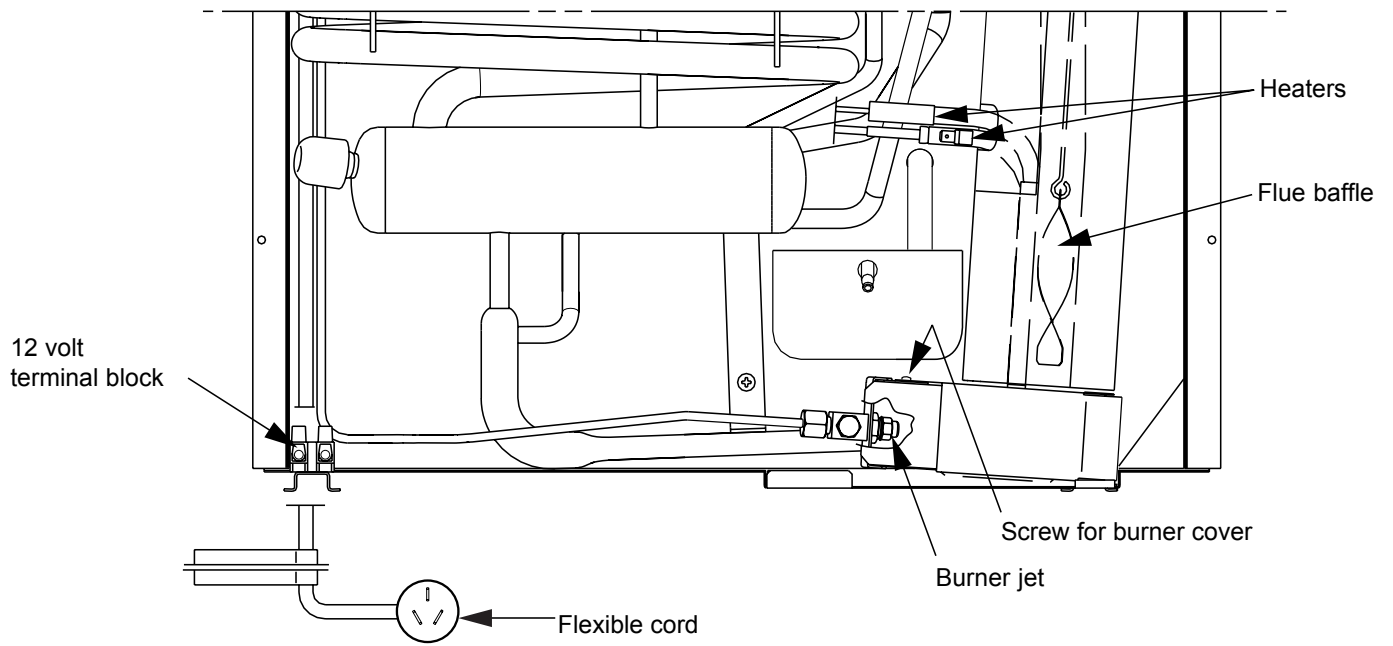

APPENDIX C - WIRING DIAGRAM

